

Schrumpfscheibe, 2-teilig, Typ 3191

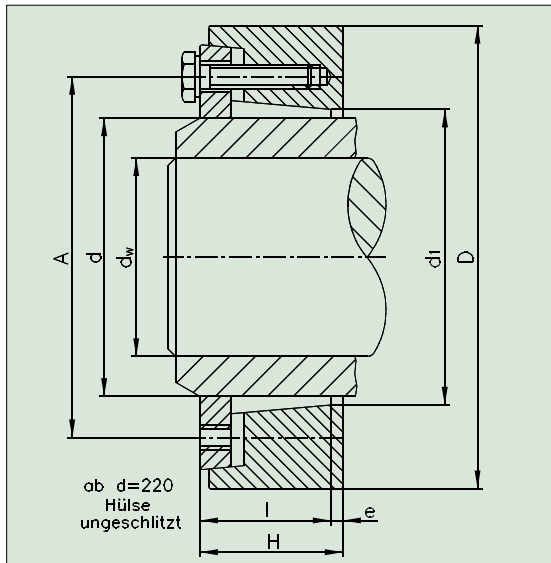

Die Maße H und e gelten für den ungespannten Zustand

M_t = übertragbares Drehmoment einer Schrumpfscheibe

M_A = erforderliches Anzugsmoment der Spannschrauben

Z - Anzahl Spannschrauben

d_w mm	d mm	M_t Nm	D mm	H mm	l mm	e mm	d_1 mm	A mm	M_A Nm	Z	DIN 933-10.9	Gewicht kg
100	140	26000	230	74	68	6	144	178	250	10	M 16x45	13
105	140	30000	230	74	68	6	144	178	250	10	M 16x45	13
110	140	33000	230	74	68	6	144	178	250	10	M 16x45	13
110	155	33000	263	80	73	7	162	196	250	12	M 16x45	19
115	155	37000	263	80	73	7	162	196	250	12	M 16x45	19
120	155	41000	263	80	73	7	162	196	250	12	M 16x45	19
120	165	47000	290	88	80	8	173	204	250	15	M 16x45	26
125	165	52000	290	88	80	8	173	204	250	15	M 16x45	26
130	165	57000	290	88	80	8	173	204	250	15	M 16x45	26
130	175	58000	300	88	80	8	183	214	250	15	M 16x45	30
135	175	63000	300	88	80	8	183	214	250	15	M 16x45	30
140	175	69000	300	88	80	8	183	214	250	15	M 16x45	30
140	185	84000	330	112	102	10	194	236	490	12	M 20x60	49
145	185	91000	330	112	102	10	194	236	490	12	M 20x60	49
150	185	99000	330	112	102	10	194	236	490	12	M 20x60	49
150	200	104000	350	112	102	10	205	246	490	14	M 20x60	54
155	200	113000	350	112	102	10	205	246	490	14	M 20x60	54
160	200	121000	350	112	102	10	205	246	490	14	M 20x60	54
160	220	127000	370	134	124	10	225	270	490	20	M 20x60	70
165	220	137000	370	134	124	10	225	270	490	20	M 20x60	70
170	220	147000	370	134	124	10	225	270	490	20	M 20x60	70
170	240	157000	405	144	132	12	248	298	490	20	M 20x60	91
180	240	180000	405	144	132	12	248	298	490	20	M 20x60	91
190	240	204000	405	144	132	12	248	298	490	20	M 20x60	91
190	260	230000	430	160	148	12	266	326	490	22	M 20x60	110
200	260	260000	430	160	148	12	266	326	490	22	M 20x60	110
210	260	292000	430	160	148	12	266	326	490	22	M 20x60	110
210	280	284000	460	172	160	12	289	346	840	18	M 24x70	136
220	280	317000	460	172	160	12	289	346	840	18	M 24x70	136
230	280	352000	460	172	160	12	289	346	840	18	M 24x70	136
230	300	360000	485	176	164	12	305	366	840	21	M 24x70	156
240	300	398000	485	176	164	12	305	366	840	21	M 24x70	156
245	300	417000	485	176	164	12	305	366	840	21	M 24x70	156
240	320	430000	520	184	170	14	325	380	840	22	M 24x70	183
250	320	473000	520	184	170	14	325	380	840	22	M 24x70	183
260	320	518000	520	184	170	14	325	380	840	22	M 24x70	183
250	340	551000	570	200	186	14	348	414	1250	18	M 27x80	248
260	340	603000	570	200	186	14	348	414	1250	18	M 27x80	248
270	340	657000	570	200	186	14	348	414	1250	18	M 27x80	248

Schrumpfscheibe, 2-teilig, Typ 3191

d _w mm	d mm	M _t Nm	D mm	H mm	l mm	e mm	d ₁ mm	A mm	M _A Nm	Z	DIN 933-10.9	Gewicht kg
270	360	671000	590	210	195	22	368	434	1250	20	M 27x80	270
280	360	729000	590	210	195	22	368	434	1250	20	M 27x80	270
290	360	789000	590	210	195	22	368	434	1250	20	M 27x80	270
290	390	850000	650	220	205	15	398	470	1250	21	M 27x90	350
300	390	917000	650	220	205	15	398	470	1250	21	M 27x90	350
310	390	988000	650	220	205	15	398	470	1250	21	M 27x90	350