

ERFORDERLICHER NABENAUSSENDURCHMESSER D_N

(rechnerische Mindestwerte) in Abhängigkeit von der Streckgrenze des Nabenmaterials

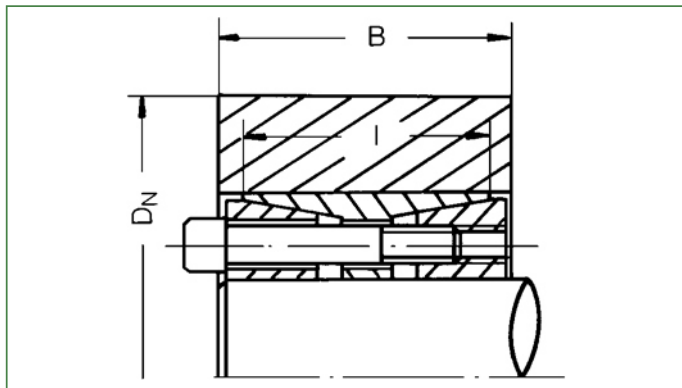

Die Tabellenwerte für D_N gelten bei Verwendung von einem Spannsatz TAS 3015

Nabenbreite $B \geq l$

Nabenquerschnitt ungeschwächt

dxD	PN	$\sigma 0,2 \text{ N/mm}^2$								
		150	180	200	220	250	270	300	350	400
mm	N/mm ²		GG-26 GS-38 V2A-S V2A-E	GG-30 V4A-S GTS-35	GS-45 St 35 St 37-3 V4A-E	GS-52 GS-C 25 GGG-40 St 45	C 35 St 50-2 X8CrTi 17 AlCuNiC	GS-60 St 60-2 C 20 GTS-45	GS-62 St 70-2 St 52	GS-70 C 60 25CrMo4
		GG-22	V2A-E							
70x110	107	280	225	205	190	176	169	161	152	146
80x120	123	395	282	250	229	208	198	187	174	167
90x135	125	448	294	280	258	234	223	210	196	190
100x145	126	481	340	300	277	251	240	226	219	201
110x155	118	465	347	310	285	261	250	237	222	212
120x165	122	495	370	344	304	285	272	264	239	230
130x180	128	673	448	392	355	320	304	286	266	252
140x190	130	710	473	412	375	338	321	302	281	266
150x200	123	664	470	416	382	346	330	312	290	278
160x210	125	697	493	437	401	363	347	327	305	292
170x225	133	978	596	511	459	412	389	364	338	317
180x235	127	878	585	510	469	418	398	374	348	329
190x250	103	595	488	432	420	390	378	360	340	327
200x260	124	836	611	540	497	450	430	405	377	361
220x285	113	783	607	550	510	468	450	427	402	385
240x305	140	1775	863	726	646	573	543	506	467	433
260x325	138	1894	920	774	689	611	579	540	497	461
280x355	141	2070	1015	507	753	667	632	589	543	504
300x375	134	1631	993	851	765	686	649	607	562	529
320x405	125	1344	952	842	774	700	668	632	587	563
340x425	119	1275	952	850	782	718	684	650	608	582
360x455	118	1365	1020	910	837	768	733	696	651	623
380x475	113	1306	1010	917	850	780	750	712	670	641
400x495	122	1643	1163	990	911	856	817	772	718	688
420x515	127	1926	1282	1118	1014	917	870	819	762	721
440x535	123	1776	1257	1113	1022	925	883	835	776	743
460x555	118	1665	1243	1110	1020	938	894	849	794	760
480x575	119	1725	1288	1150	1060	972	926	880	822	788
500x595	115	1636	1267	1148	1065	976	940	892	839	803
520x615	124	2040	1445	1280	1175	1064	1015	959	892	855
540x635	120	1905	1422	1270	1168	1073	1022	972	908	870
560x655	125	2174	1540	1362	1250	1133	1081	1021	950	910
580x675	121	2025	1512	1350	1242	1140	1087	1033	965	938
600x695	118	2085	1556	1390	1278	1175	1120	1063	994	952