

ERFORDERLICHER NABENAUSSENDURCHMESSER D_N

(rechnerische Mindestwerte) in Abhängigkeit von der Streckgrenze des Nabenmaterials

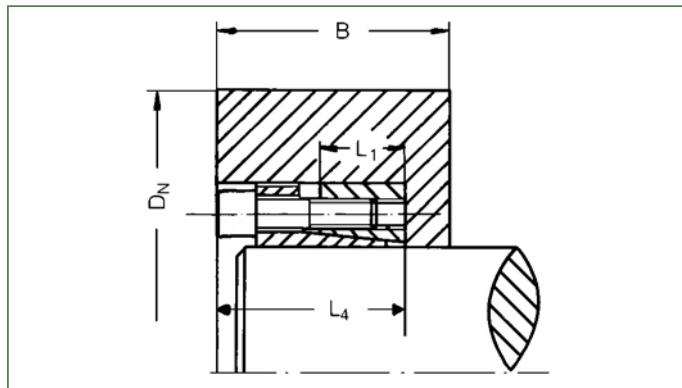

Die Tabellenwerte für D_N gelten bei Verwendung von einem Spannsatz TAS 3003

Nabenbreite $B \geq 2 L_1$

Bohrungstiefe $b \geq L_4$

Nabenquerschnitt ungeschwächt

dxD	PN	$\sigma 0,2 \text{ N/mm}^2$								
		150	180	200	220	250	270	300	350	400
mm	N/mm ²		GG-26 GS-38 V2A-S V2A-E	GG-30 V4A-S GTS-35	GS-45 St 35 St 37-3 V4A-E	GS-52 GS-C 25 GGG-40 St 45	C 35 St 50-2 X8CrTi 17 AlCuNiC	GS-60 St 60-2 C 20 GTS-45	GS-62 St 70-2 St 52	GS-70 C 60 25CrMo4
		GG-22	V2A-E							
20x 47	100	75	70	65	65	60	60	60	57	55
25x 50	110	80	75	72	69	66	64	63	61	59
30x 55	100	85	78	75	73	71	69	68	66	64
35x 60	125	104	94	89	86	82	80	78	75	73
40x 65	115	108	98	93	90	87	85	83	80	78
45x 75	135	138	123	116	111	105	102	99	96	93
50x 80	130	143	128	121	116	111	108	104	101	98
55x 85	140	163	142	133	128	121	118	114	109	105
60x 90	130	161	143	136	131	125	122	117	114	110
65x 95	140	182	158	149	143	135	132	127	122	117
70x110	140	211	183	172	165	157	152	147	141	136
75x115	135	211	188	178	170	161	157	152	147	142
80x120	130	214	191	182	174	166	162	156	152	147
85x125	140	239	208	195	188	178	173	167	160	154
90x130	135	238	212	201	192	182	177	172	166	160
95x135	145	262	229	215	206	195	189	183	175	168
100x145	145	282	246	231	221	209	203	196	188	180
110x155	135	284	253	239	228	217	211	205	197	191
120x165	140	316	274	258	248	235	228	220	212	203
130x180	135	330	294	278	265	252	245	238	229	222
140x190	130	339	303	287	276	263	257	247	240	232
150x200	140	382	332	312	300	284	276	266	256	246
160x210	145	408	355	334	320	303	294	284	271	261
170x225	115	372	338	322	311	300	293	286	275	268
180x135	115	388	353	337	325	313	306	299	287	280
190x250	130	445	398	378	363	345	338	325	315	305
200x260	120	440	398	380	367	351	344	333	323	312
220x285	110	456	419	402	388	374	365	357	345	337
240x305	125	528	476	452	437	415	406	394	382	370
260x325	140	621	540	507	488	462	449	433	416	400
280x355	120	600	543	519	501	480	469	455	441	426
300x375	125	649	585	555	537	510	499	484	469	454
320x405	120	685	620	592	572	547	535	519	503	486
340x425	135	778	693	655	625	595	578	561	540	523
360x455	115	751	683	651	628	606	592	578	556	542
380x475	130	846	756	718	689	656	642	618	599	580
400x495	125	857	773	733	708	674	659	639	619	599